

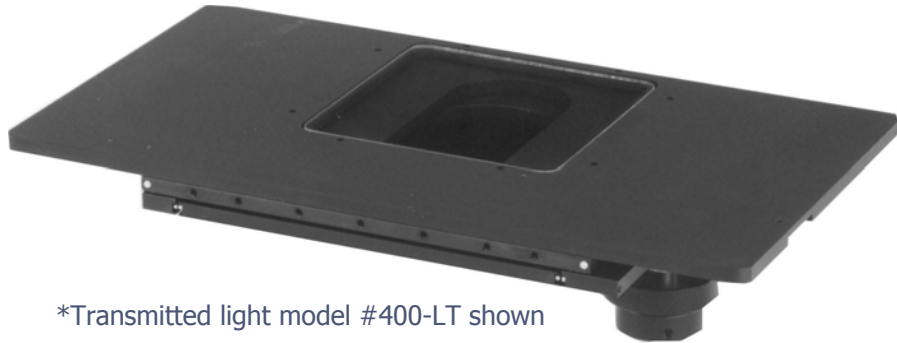

# Model #400-L 4"x4" Travel Stage

- **4 lbs. 4 oz.**
- **Black Anodized**
- **Rack and Pinion Drive**
- **Stainless Steel Raceways**
- **Smooth Ball Bearing Travel**
- **One Year Warranty**
- **Custom Holes Available**



\*Transmitted light model #400-LT shown

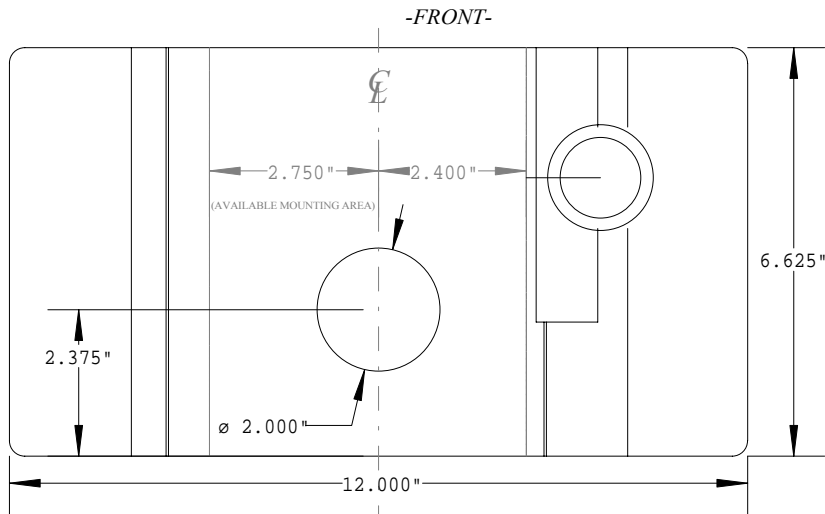
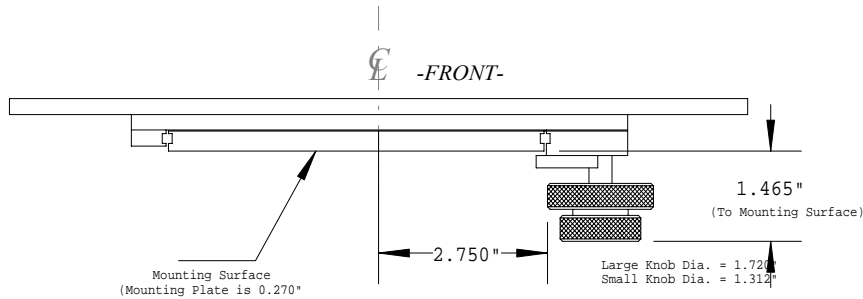

**PROPRIETARY**

This document contains information that is the sole property of Franklin Mechanical & Control Inc. and cannot be copied, reproduced or utilized in any way without the express written consent of Franklin Mechanical & Control Inc.

**Franklin Mechanical & Control, Inc.**  
**8901-B Murray Ave., Gilroy, CA 95020 408-842-0313 [www.franklinstages.com](http://www.franklinstages.com)**